

# MANUAL DE MONTAJE

## FPF3



### MAMPARA FRONTAL DE DUCHA

1 HOJA ABATIBLE+2 FIJAS

# FPF3

## 1

PRESENTAMOS PERFILES EXPANSORES DEL FIJO SOPORTE HOJA PUERTA Y HOJA FIJA DE CIERRE, EN PAREDES, SEGÚN CORESPONDA SU POSICION, NIVELANDOLOS, A 1 CM. DEL BORDE DEL PLATO DE DUCHA Y MARCAMOS TALADROS.

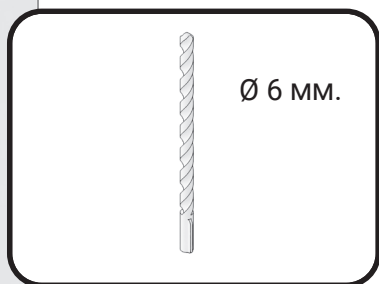
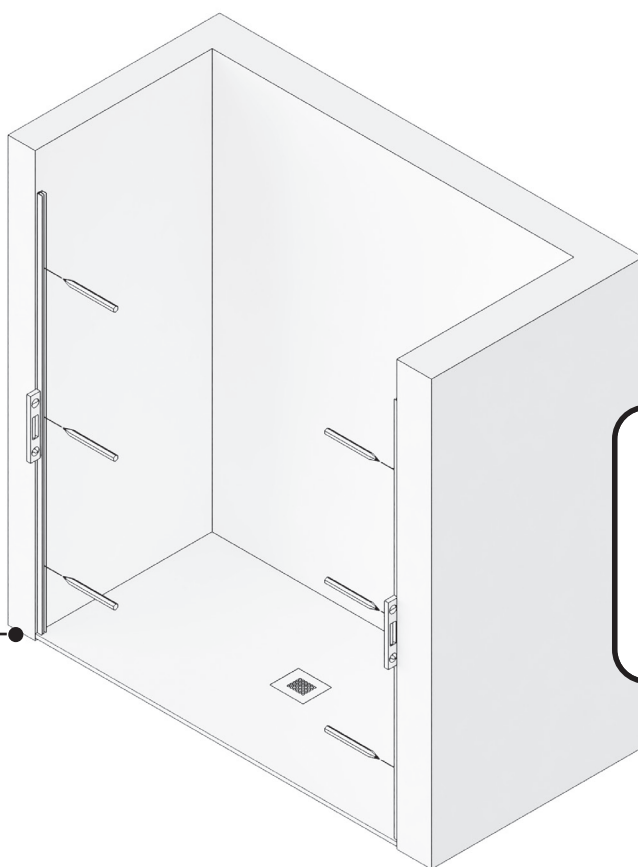
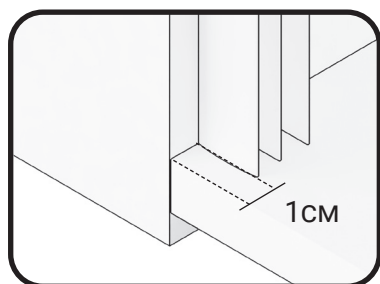

## 2

TALADRAR LA PARED CON BROCA DE 6MM.

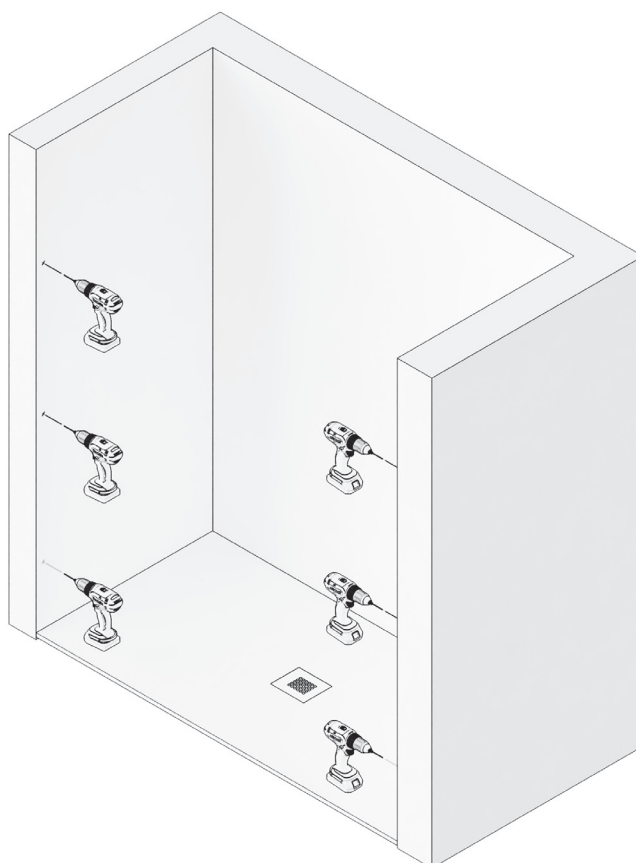

# 3

ATORNILLAR LOS PERFILES EXPANSORES DE LOS FIJOS, FIJANDOLOS CON TACOS DEL N° 6 Y LOS 6 TORNILLOS 4.2X32.



# 4

COLOCAMOS GOMA DE ESTANQUEIDAD INFERIOR Y LA GOMA BURBUJA VIDRIO-VIDRIO (CAJEADA), EN LA HOJA FIJA SOPORTE PUERTA.

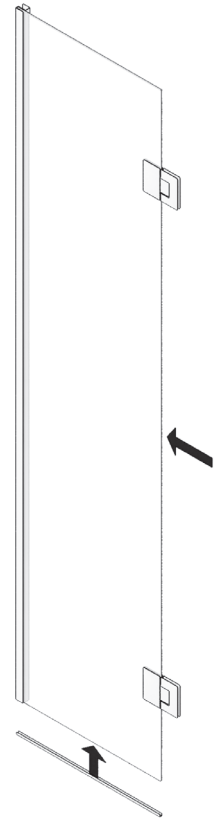

# 5

INTRODUCIMOS LA HOJA FIJA SOPORTE PUERTA PRE-MONTADA EN SU PERFIL EXPANSOR.



**FPF3**

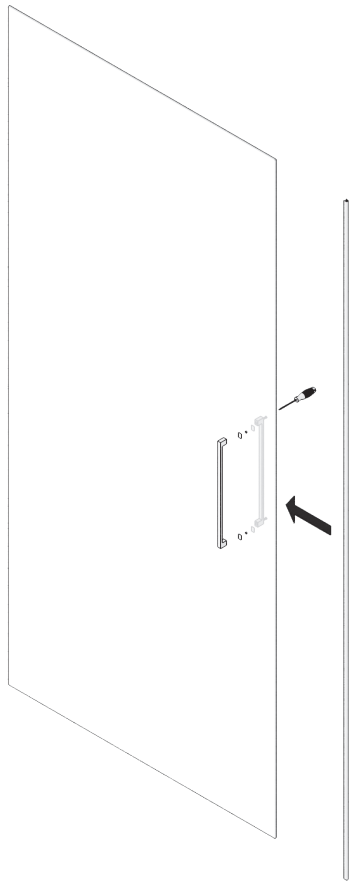

**6**

MONTAMOS ASA TIRADOR Y GOMA CIERRE IMÁN FRONTAL, EN LA HOJA ABATIBLE.

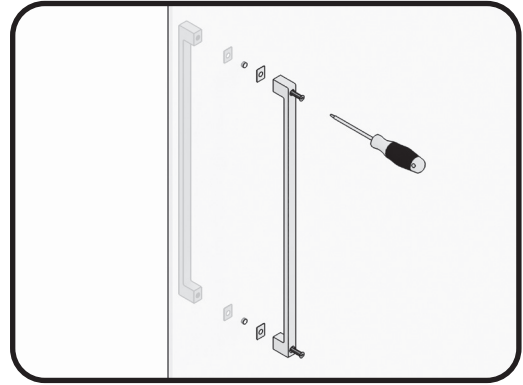

**7**

PRESENTAMOS LA HOJA ABATIBLE SOBRE LAS BISAGRAS VIDRIO-VIDRIO DE LA HOJA FIJA SOPORTE PUERTA PRE-MONTADA, ELEVANDOLA CON CALZOS 1.5 CM. SOBRE EL PLATO DE DUCHA, DESMONTANDO LAS TAPAS COGIDA BISAGRA-VIDRIO, INTRODUCIENDO LA HOJA ABATIBLE EN LAS MUESCAS CORRESPONDIENTES Y ATORNILLANDO DE NUEVO SUS TAPAS CON GOMAS A DOS CARAS.



**8**

COLOCAMOS GOMA DE ESTANQUEIDAD INFERIOR Y GOMA CIERRE IMAN EN LA HOJA FIJA CIERRE PUERTA.

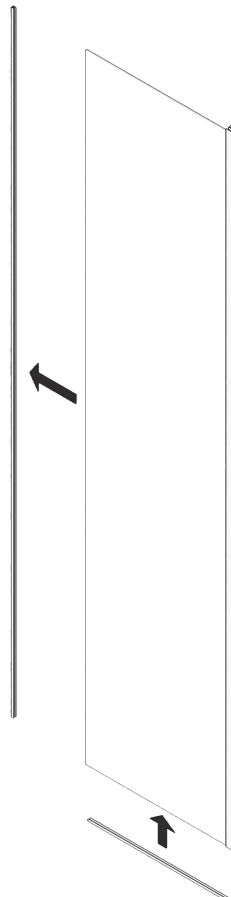

# 9

INTRODUCIMOS LA HOJA FIJA CIERRE PUERTA PRE-MONTADA EN SU MARCO EXPANSOR.



# 10

AFLOJAMOS LOS TORNILLOS DE SUJECCIÓN DE LAS TAPAS BISAGRA-VIDRIO. APROXIMAMOS Y NIVELAMOS LA HOJA ABATIBLE CON LAS HOJAS FIJAS, ENTRE VIDRIOS Y RESPECTO AL CIERRE, FIJAMOS AL CENTRO LA HOJA ABATIBLE CON LA FIJA, APRETANDO LOS TORNILLOS DE LAS TAPAS BISAGRAS-VIDRIO. FIJAMOS LAS HOJAS FIJAS LATERALES A SU CORRESPONDIENTE PERFIL EXPANSOR CON LOS 6 TORNILLOS AUTORROSCANTES CON BASES Y COLOCAMOS SUS RESPECTIVOS TAPONES EMBELLECEDORES, POR EL INTERIOR DE LA DUCHA.

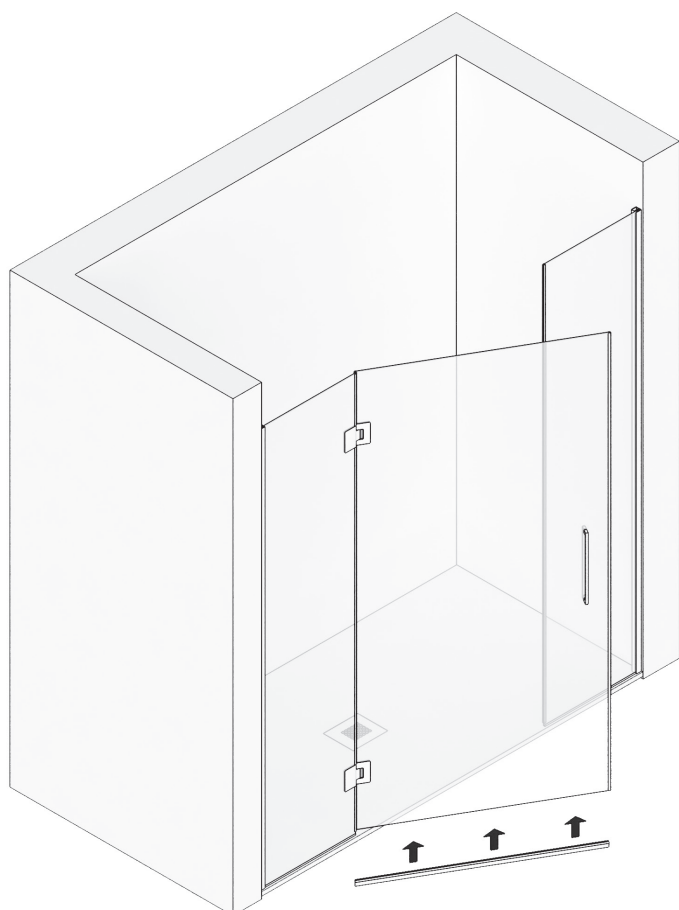
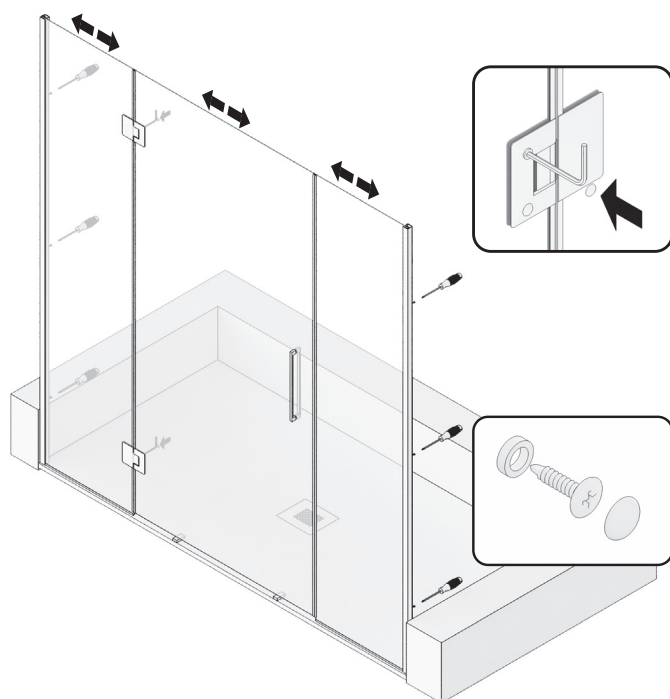

# 11

RETIRAMOS LOS CALZOS DE LA HOJA ABATIBLE, COLOCAMOS LA GOMA INFERIOR BARREDERA.

FPF3

# 12

PRESENTAMOS, NIVELAMOS Y MARCAMOS LOS BRAZOS DE SUJECCIÓN SUPERIOR DE LAS HOJAS FIJAS, AJUSTANDO LA DISTANCIA AL CORTE DE LOS TUBOS DEL MISMO Y FIJAMOS A PARED Y VIDRIO.

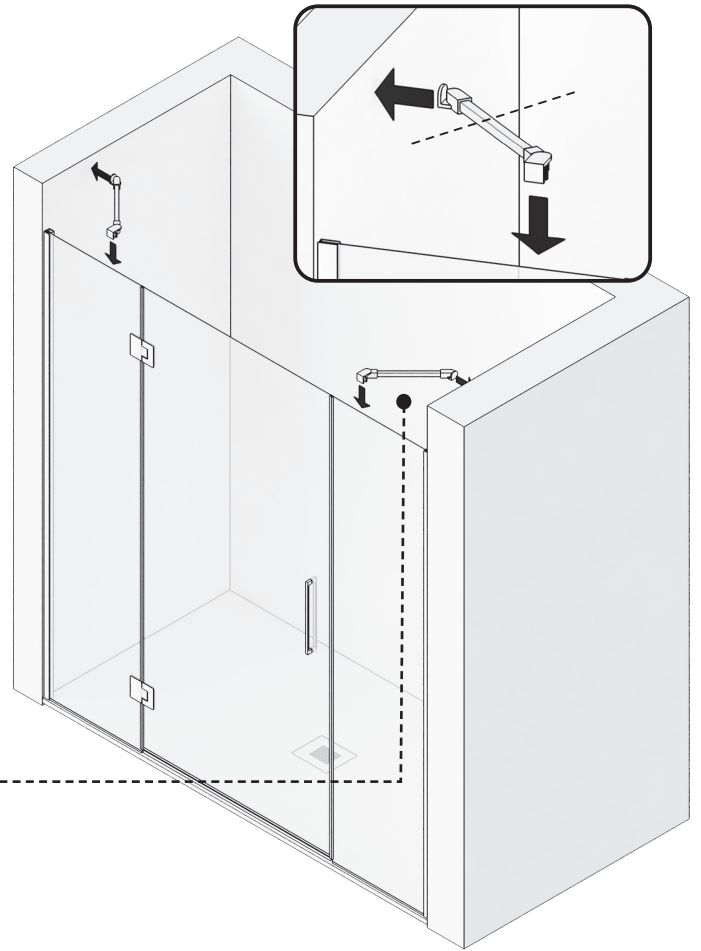
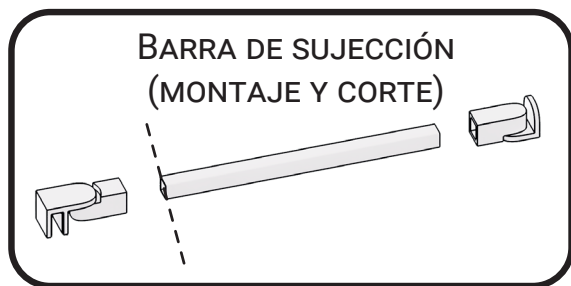

# 13

MEDIMOS, CORTAMOS Y PEGAMOS EL PERFIL DE ESTANQUEIDAD POR DELANTE DE LA HOJA ABATIBLE.

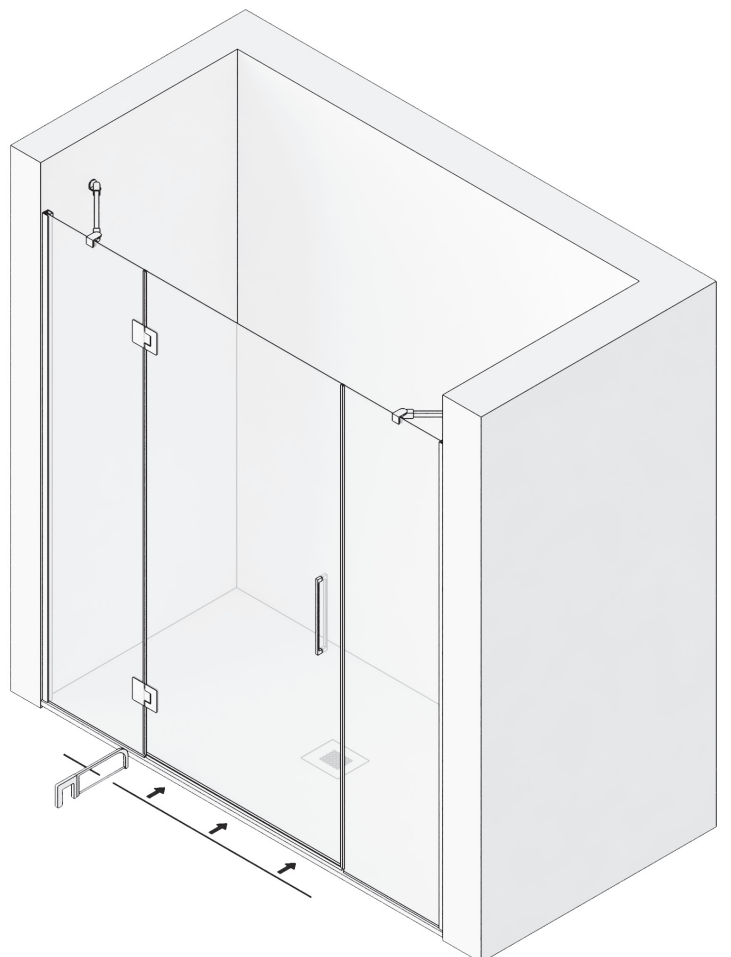
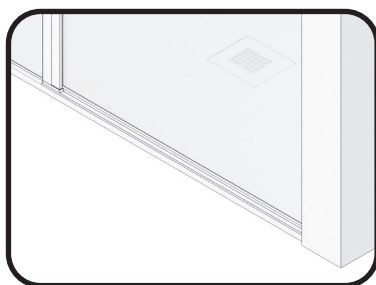

# 14

COLOCAMOS LAS 2 TAPAS  
EMBELLECEDORAS SUPERIORES EN LOS  
PERFILES EXPANSORES DE LAS HOJAS  
FIJAS.

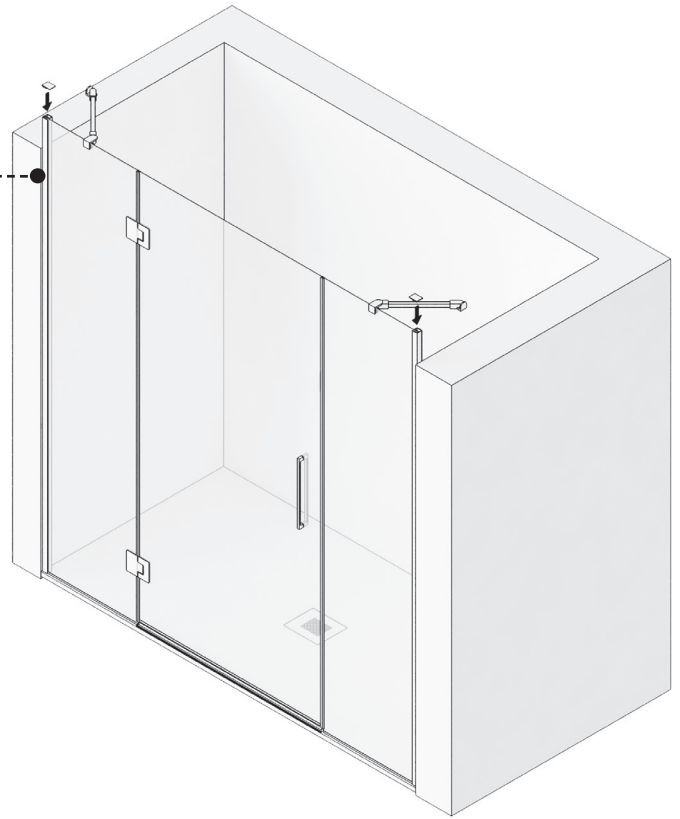
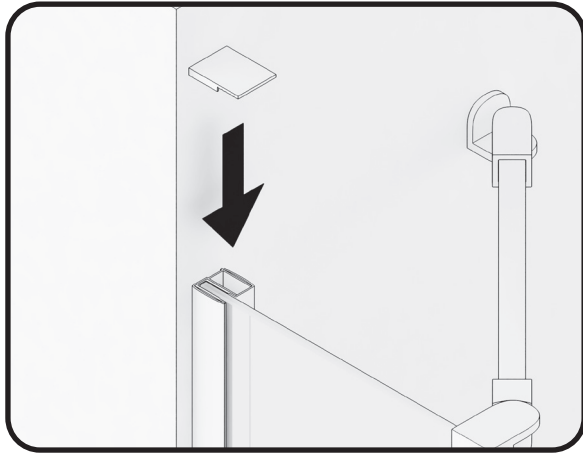

# 15

SELLAR CON SILICONA EL CONTORNO  
EXTERIOR DE LA MAMPARA.

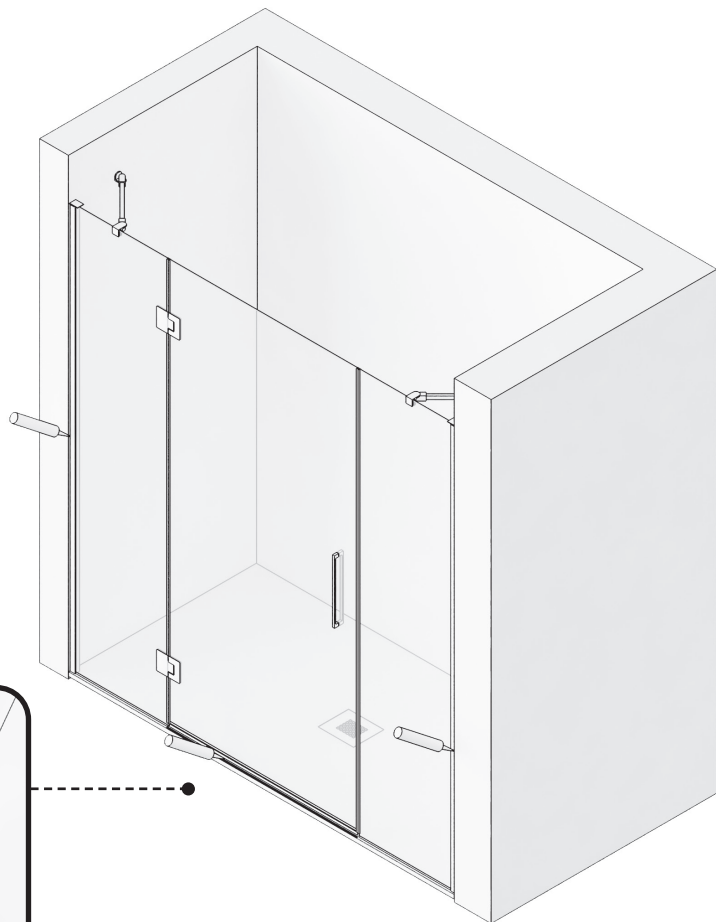
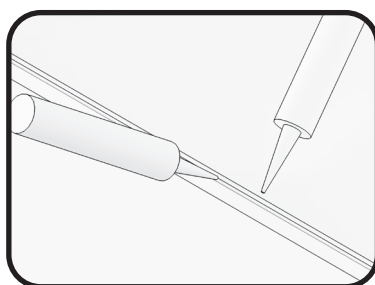

# FPF3

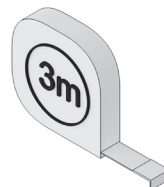
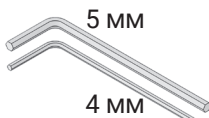
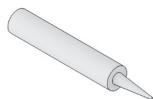
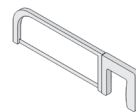
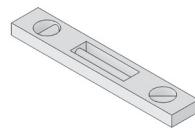
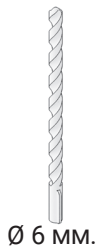
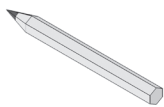

**1X**



HOJA ABATIBLE

**2X**

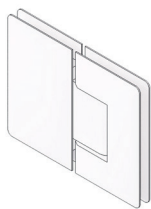

BISAGRAS VIDRIO-VIDRIO  
DE ACERO INOX

**2X**



HOJA FIJA PRE-MONTADA

**2X**



PERFIL EXPANSOR HOJA FIJA

**2X**

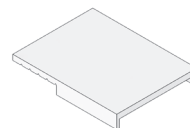

TAPA PERFIL EXPANSOR  
HOJA FIJA.

**2X**



BARRA DE SUJECCIÓN FIJO

**1X**



ASA TIRADOR.

**1X**

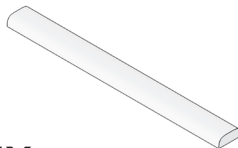

PERFIL DE ESTANQUEIDAD.

**1X**



GOMA BURBUJA

**2X**



GOMA IMÁN FRONTAL

**1X**

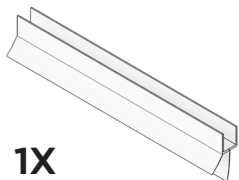

GOMA INFERIOR BARREDERA.

**1X**

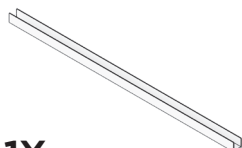

GOMA ESTANQUEIDAD FIJO

**6X**

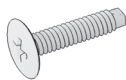

TORNILLOS  
AUTORROSCANTES

**6X**

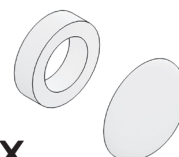

TAPONES CON BASES.

**6X**

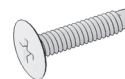

TORNILLOS 4.2 X 32

**6X**



TACOS N°6