

MANUAL DE MONTAJE

APF2



MAMPARA ANGULAR DE DUCHA

1 HOJA ABATIBLE + 1 FIJA

APF2



1

PRESENTAMOS LA HOJA ABATIBLE PRE-MONTADA EN PARED, SEGÚN CORRESPONDA SU POSICIÓN, ELEVANDOLA CON CALZOS 1.5 CM SOBRE EL PLATO DE DUCHA NIVELANDOLA A 1 CM DEL BORDE DEL MISMO Y MARCAMOS LOS TALADROS DE LAS PLACAS BISAGRAS.

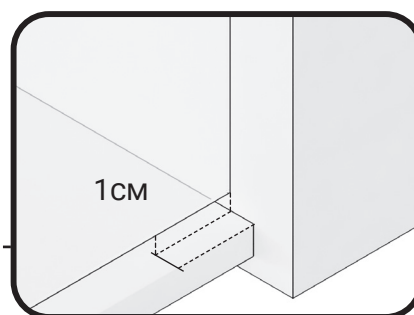

2

TALADRAR LA PARED CON BROCA Ø 6 MM.

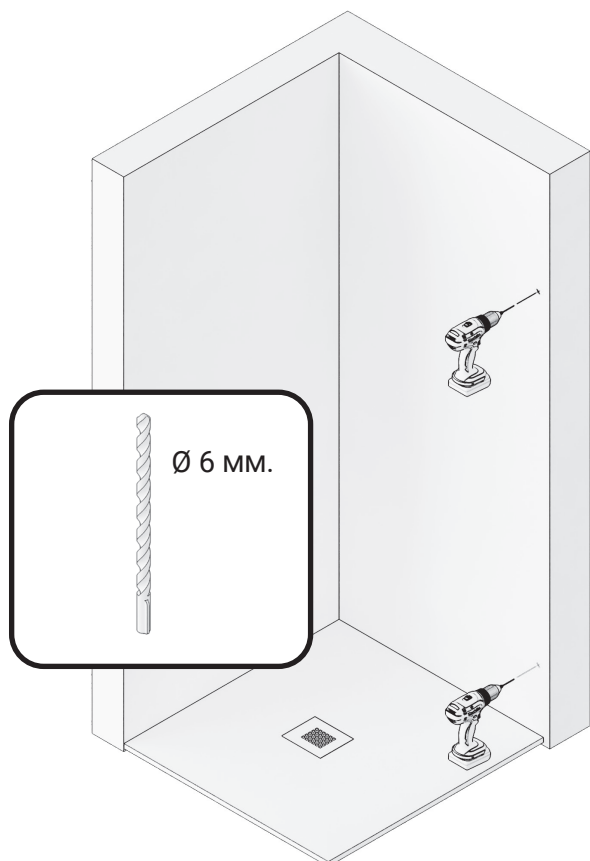

3

ATORNILLAR LAS PLACAS BISAGRAS DE LA HOJA ABATIBLE, FIJANDOLA CON TACOS DEL N° 6 Y LOS 8 TORNILLOS 3.5 X 32.



4

MONTAMOS ASA TIRADOR Y GOMA CIERRE IMÁN FRONTAL EN LA HOJA ABATIBLE.

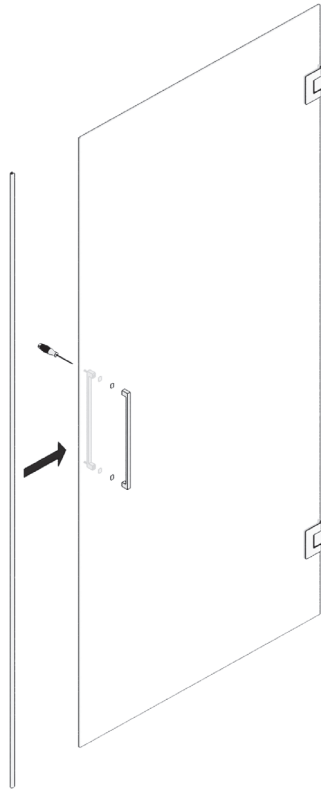
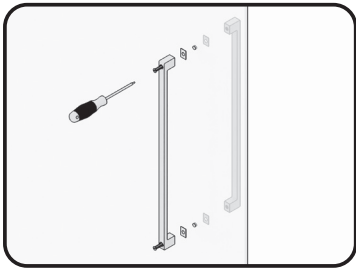

5

PRESENTAMOS PERFIL EXPANSOR HOJA FIJA EN PARED, SEGÚN CORRESPONDA SU POSICIÓN, NIVELÁNDOLO, A 1 CM DE BORDE EXTERIOR DEL PLATO DUCHA Y MARCAMOS TALADROS.

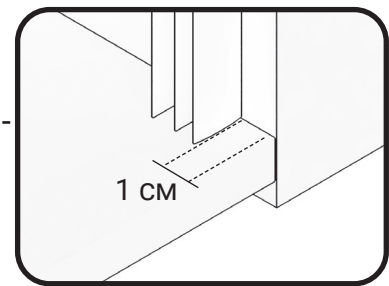

EXPANSOR HOJA FIJA

6

TALADRAR LA PARED CON BROCA DE 6MM.

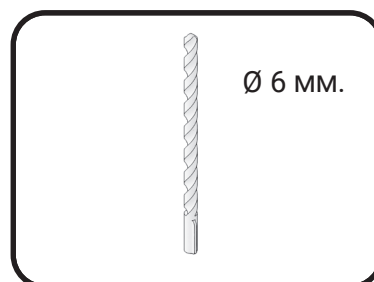

7

ATORNILLAR EL PERFIL EXPANSOR HOJA FIJA A PARED, FIJÁNDOLO CON TACOS DEL N°6 Y LOS 3 TORNILLOS 4.2 X 32.



8

COLOCAMOS GOMA DE ESTANQUEIDAD INFERIOR Y GOMA CIERRE IMÁN FRONTAL EN LA HOJA LATERAL FIJA.

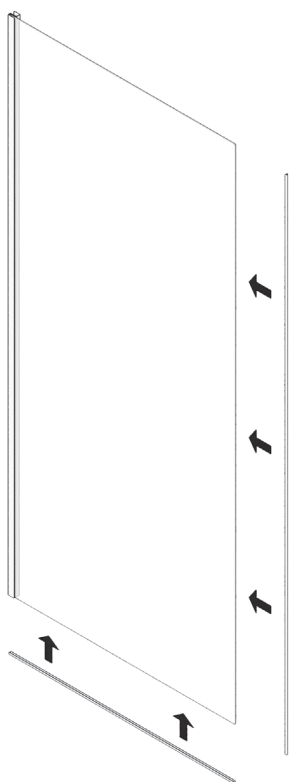

9

INTRODUCIMOS LA HOJA LATERAL FIJA PRE-MONTADA EN SU MARCO EXPANSOR.



10

AFLOJAMOS LOS TORNILLOS DE SUJECCIÓN DE LA TAPA BISAGRA-VIDRIO.

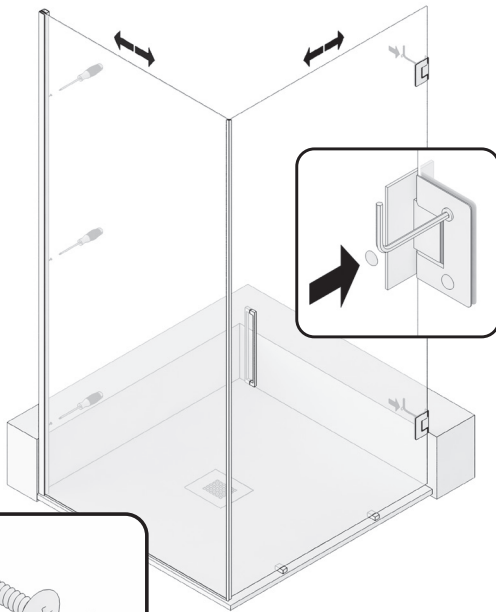
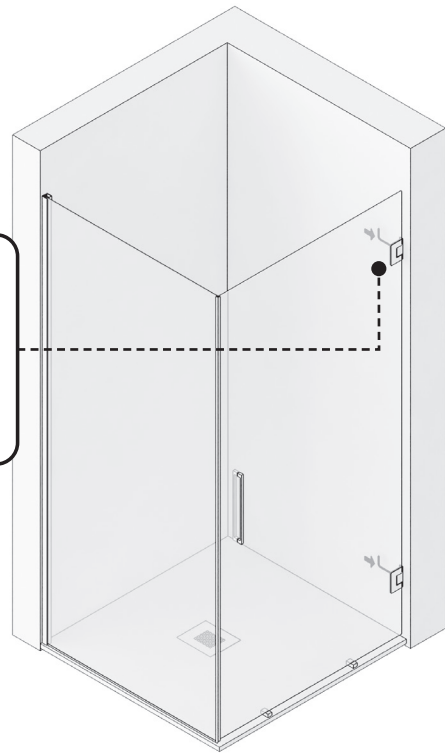
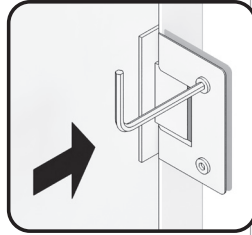

11

APROXIMAMOS Y NIVELAMOS LA HOJA ABATIBLE Y LA HOJA LATERAL FIJA RESPECTO AL CIERRE AL VÉRTICE, FIJAMOS LA HOJA ABATIBLE, APRETANDO LOS TORNILLOS DE LAS TAPAS BISAGRAS-VIDRIO, FIJAMOS LA HOJA FIJA A SU CORRESPONDIENTE PERFIL EXPANSOR CON LOS 3 TORNILLOS AUTORROSCANTES CON BASES Y COLOCAMOS LOS TAPONES EMBELLECEDORES SOBRE LOS MISMOS, POR EL INTERIOR DE LA DUCHA.

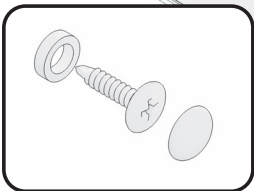

12

RETIRAMOS LOS CALZOS DEL VIDRIO, COLOCAMOS GOMA INFERIOR BARREDERA Y GOMA BURBUJA (CAJEADAS) CONTRA LA PARED EN LADO BISAGRAS.



APF2

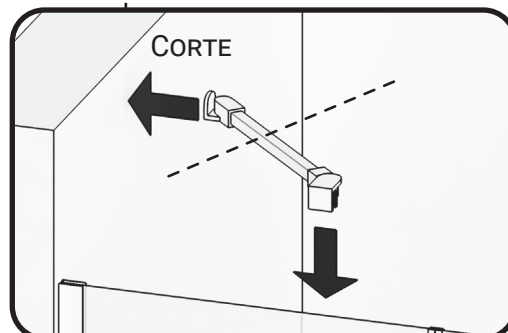
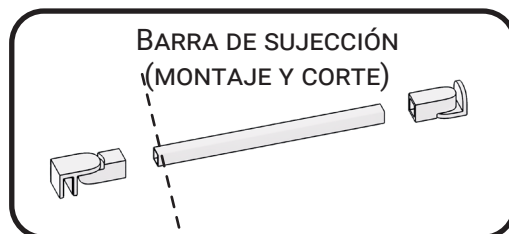

13

PRESENTAMOS, NIVELAMOS Y MARCAMOS EL BRAZO DE SUJECCIÓN SUPERIOR DE LA HOJA FIJA, AJUSTANDO LA DISTANCIA AL CORTE DEL TUBO DEL MISMO Y FIJAMOS A PARED Y VIDRIO.

14

MEDIMOS, CORTAMOS Y PEGAMOS EL PERFIL DE ESTANQUEIDAD POR DELANTE DE LA HOJA ABATIBLE.

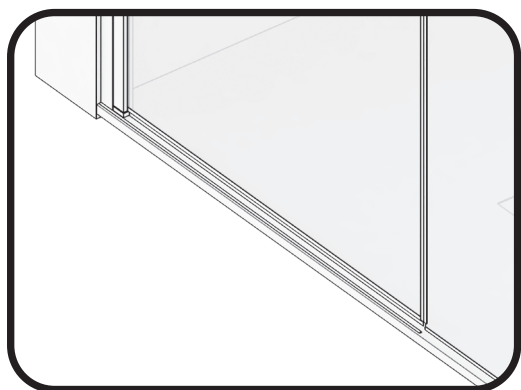

15

COLOCAMOS LA TAPA EMBELLECEDORA SUPERIOR EN EL PERFIL EXPANSOR DE LA HOJA LATERAL FIJA.

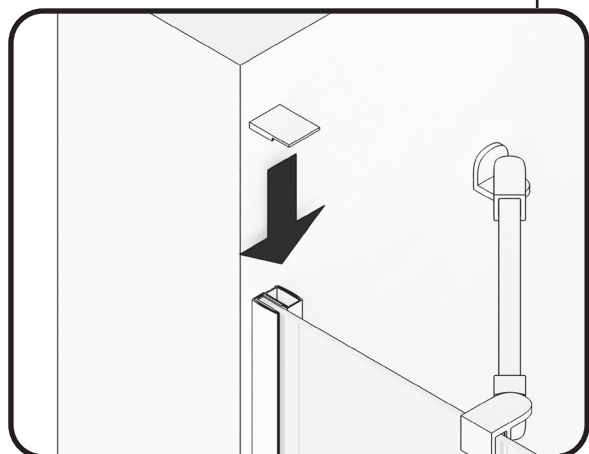





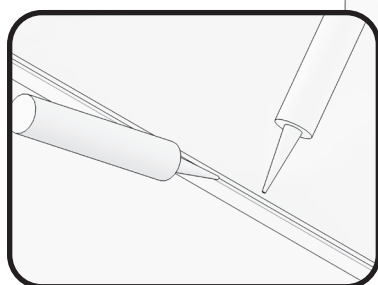



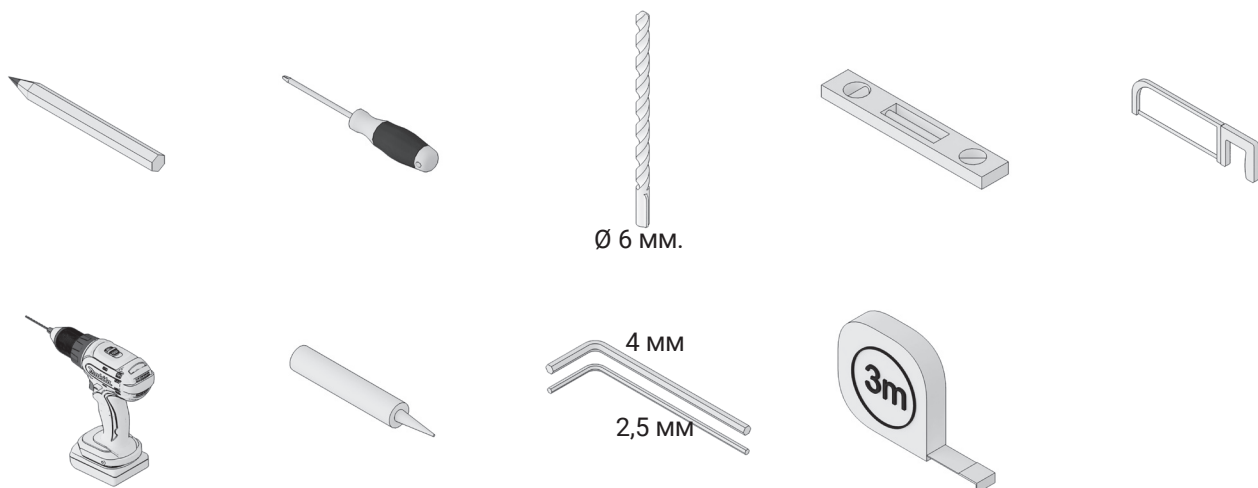

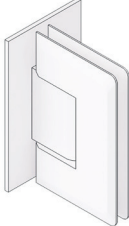

16

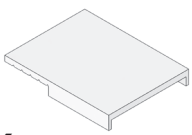
SELLAR CON SILICONA EL CONTORNO EXTERIOR DE LA MAMPARA.

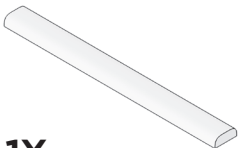

APF2

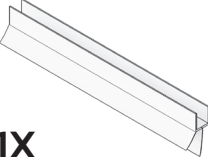
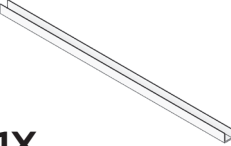
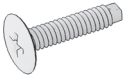
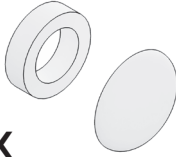
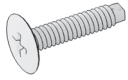
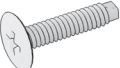

- 1X**  HOJA ABATIBLE PRE-MONTADA
- 2X**  BISAGRAS A PARED DE ACERO INOX
- 1X**  HOJA FIJA PRE-MONTADA
- 1X**  PERFIL EXPANSOR HOJA FIJA
- 1X**  TAPA PERFIL EXPANSOR HOJA FIJA
- 1X**  BARRA DE SUJECCIÓN FIJO
- 1X**  ASA TIRADOR.
- 1X**  GOMA BURBUJA
- 1X**  PERFIL DE ESTANQUEIDAD
- 2X**  GOMA IMÁN ANGULAR.
- 1X**  GOMA INFERIOR BARREDERA
- 1X**  GOMA ESTANQUEIDAD FIJO
- 3X**  TORNILLOS AUTORROSCANTES
- 3X**  TAPONES CON BASES
- 3X**  TORNILLOS 4.2 X 32
- 8X**  TORNILLOS 3.5 X 32
- 11X**  TACOS N°6