

MANUAL DE MONTAJE

A3



MAMPARA ANGULAR DE DUCHA

1 HOJA CORREDERA + 2 FIJAS

A3

1

PRESENTAR "U" EN PARED
Y MARCAR LOS TALADROS
EN AMBOS LADOS.

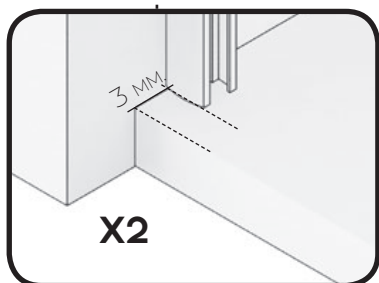
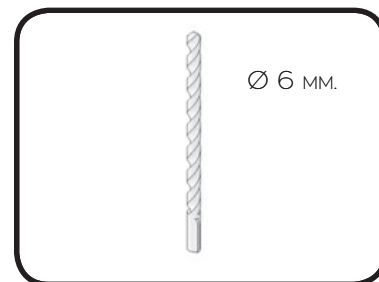

2

TALADRAR CON
BROCA Ø 6 MM.



3

ATORNILLAR LA "U" A PARED
USANDO TACOS DE N° 6
TORNILLOS 4,2 x 32.
EN AMBOS LADOS.

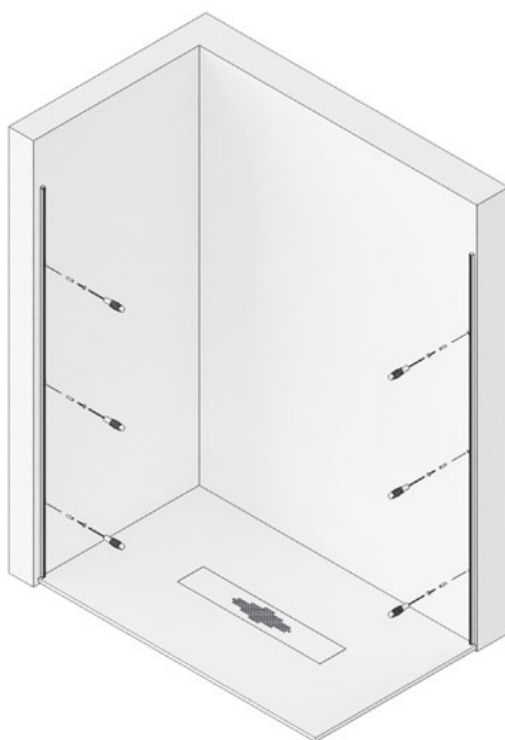

4

COLOCAR GOMAS ESTANQUEIDAD INFERIOR FIJOS E INTRODUCIR LOS CRISTALES FIJO EN LA "U" APOYANDO SOBRE ÉSTA.

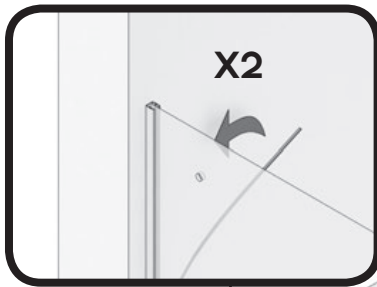

5

ENGOMAR CRISTALES FIJOS A "U" Y COLOCAR LA PINZA GUÍA INFERIOR EN EL EXTREMO DEL VIDRIO.



PINZA GUIA INFERIOR

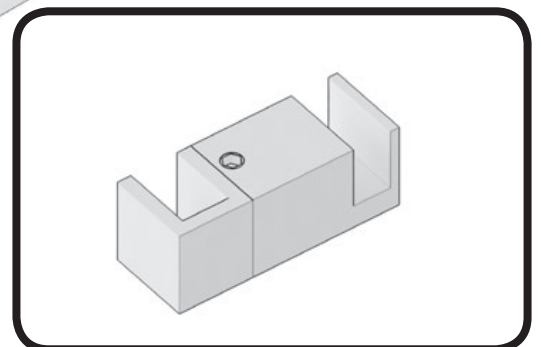
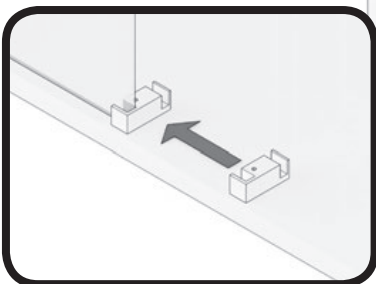

A3

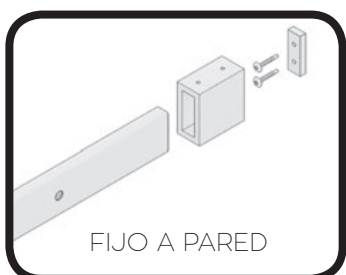
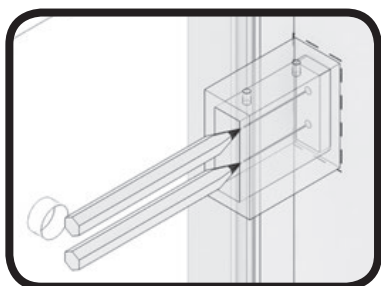

FIJO A PARED

A CONTINUACIÓN DESMONTAR PLACA BASE DEL SOPORTE VASO, SOLTANDO EL TORNILLO PRISINERO, MARCAR TALADROS.

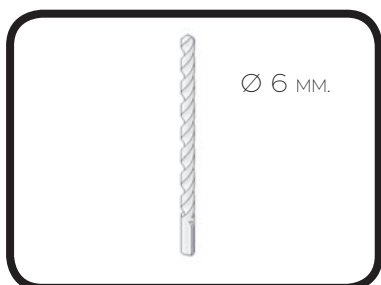

Ø 6 MM.

7

TALADRAR CON BROCA DE Ø 6 MM.



RETIRAR CRISTAL FIJO SI FUESE NECESARIO..

6

PRESENTAR GUÍA SUPERIOR CON LOS VASOS SOBRE LOS VIDRIOS FIJOS, HACIENDO COINCIDIR LOS TALADROS GUÍA CON LOS DE LOS VIDRIOS, NIVELAR Y MARCAR EL CONTORNO EXTERIOR DE LOS VASOS. A PARED.

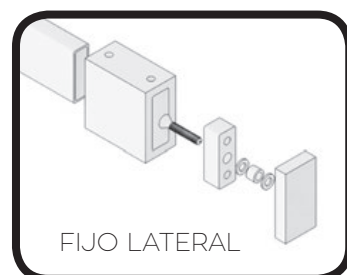

FIJO LATERAL

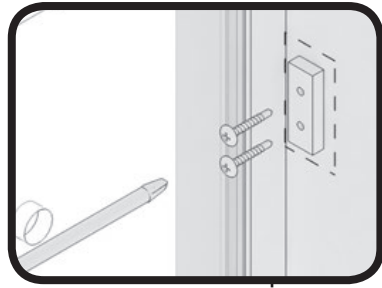

8

ATORNILLAR LA PLACA BASE SOPORTE GUÍA SUPERIOR A PARED.



9

INTRODUCIR EL TOPE FRENO EN LA GUÍA. Y LOS VASOS SOPORTE GUÍA.

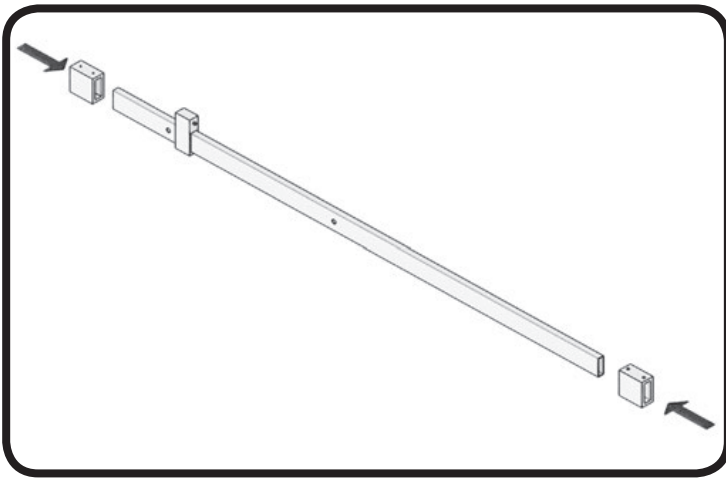

10

COLOCAR LA GUÍA SUPERIOR EN LA BASE COGIDA A PARED, FIJAR LA COGIDAS A LA GUÍA Y ESTA A LOS TALADROS DEL FIJO CON LAS SUJECIONES.

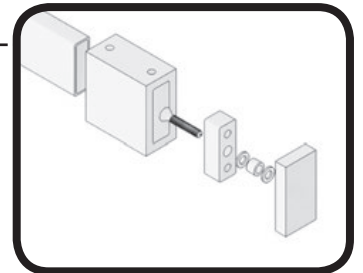
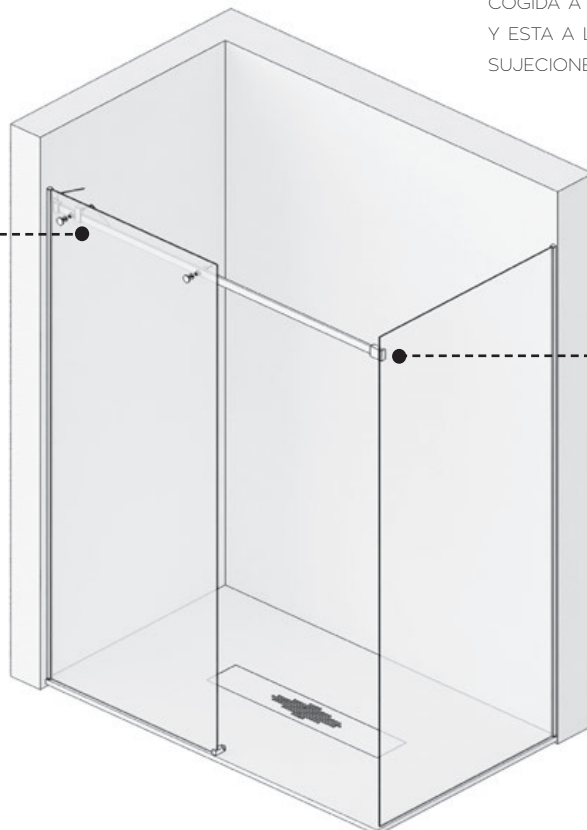
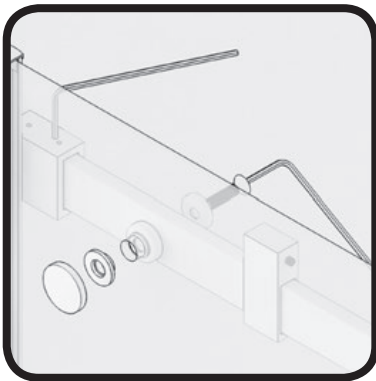

11

COLOCAR LOS RODAMIENTOS EN LA HOJA CORREDERA, COLGAR LA PUERTA INTRODUCIENDO PREVIAMENTE LA GOMA DE "U" EN EL CANTO INFERIOR. GRADUAR RUEDAS, GIRANDO CON LA LLEVE ALLEN ANTES DE FIJAR.

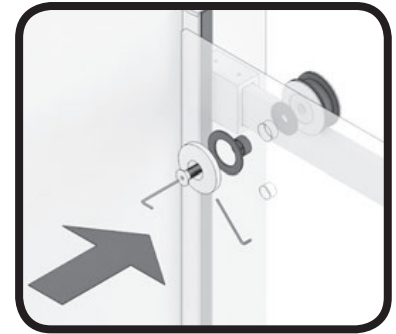
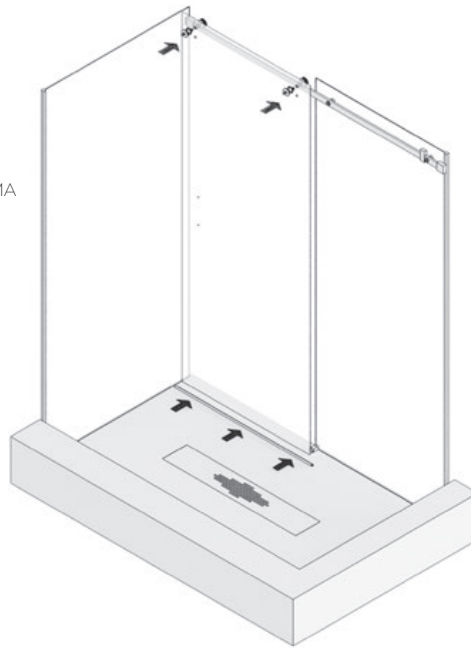

12

MONTAR Y AJUSTAR LOS PERNOS ANTIVUELCO, COLOCAR EL ASA TIRADOR.

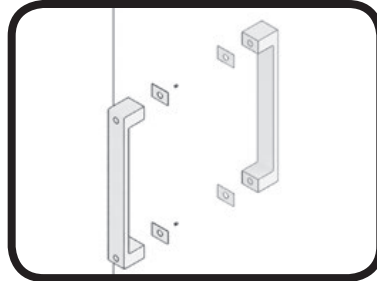

13

COLOCAR LAS GOMAS DE CRUCE, UNA EN EL FIJO Y OTRA EN LA HOJA CORREDERA. COLOCAR EL CIERRE GOMA IMÁN EN EL EXTREMO DE LA HOJA CORREDERA Y PRESENTAR SOBRE EL MISMO EL IMÁN ADHESIVO SOBRE EL LATERAL PARA PEGAR, LIMPIANDO PREVIAMENTE LA SUPERFICIE DEL VIDRIO PARA SU MEJOR ADHERENCIA.

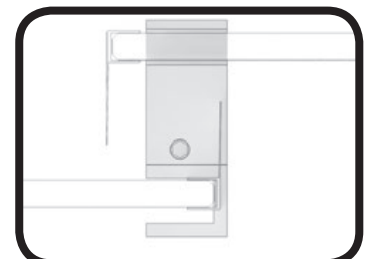
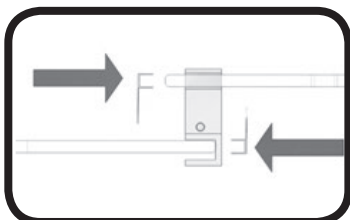

14

FIJAR EL TOPE FRENO MEDIANTE EL TORNILLO PRISIONERO..

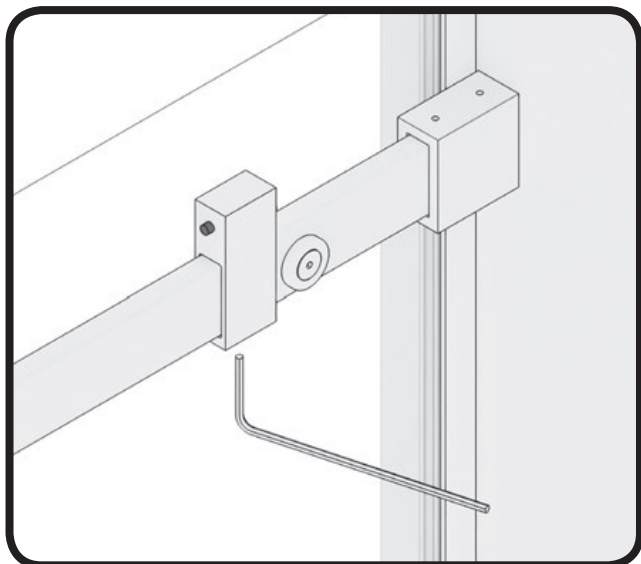

15

CORTAR EL PERFIL BAJO A MEDIDA. DESDE LA PINZA BAJA HASTA EL TERMINAL EMBELLECEDOR DEL FIJO Y COLOCAR POR DELANTE DE LA HOJA CORREDERA.



16

PEGAR PERFIL BAJO CON SILICONA.

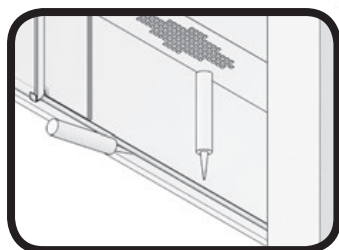

17

SELLAR CON SILICONA EL CONTORNO EXTERIOR DE LA MAMPARA.



A3



Ø 6 MM.

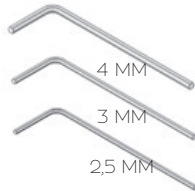
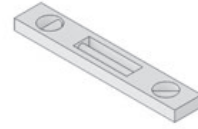

4 MM

3 MM

2,5 MM

1X



FIJO LATERAL

1X



HOJA FIJA

1X



HOJA CORREDERA

2X



PERNO ANTIVUELCO

2X



RODAMIENTO SUPERIOR

2X



SUJECIÓN FIJO-GUÍA

1X

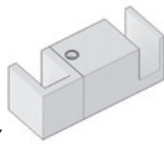

PINZA GUÍA INFERIOR

1X



TOPE FRENO

1X



VASO SOPORTE GUÍA

1X

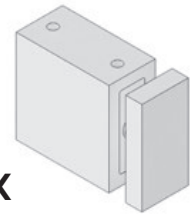

VASO SOPORTE FIJO

1X

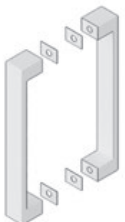

ASA TIRADOR

10X



Tacos nº6

10X



Tornillo 4,2 X 32

2X



TAPA PERFIL "U" FIJO A PARED

1X



TERMINAL EMBELLECEDOR L / FIJO

2X



PERFIL "U" FIJO A PARED

1X



CIERRE ÍMÁN ADHESIVO

1X



PERFIL GUÍA SUPERIOR

1X



PERFIL VIERTEAGUAS

2X



GOMAS DE ALA CRUCE FIJO/CORREDERA

1X



CIERRE ÍMÁN HOJA

1X



GOMA ESTANQUEIDAD INFERIOR FIJO

1X



GOMA ESTANQUEIDAD PUERTA INFERIOR

2X



GOMA FIJO "U"

fabricación nacional